

# **AKIRA**

makes life better

---

## **Air Conditioner Service Manual**



Большая библиотека технической документации

<https://splitsystema48.ru/instrukcii-po-ekspluatcii-kondicionerov.html>

каталоги, инструкции, сервисные мануалы, схемы.

# Model: AC-S10CG

## Content

Technical specification.....	4
Performance curve.....	5
Outline & dimension of indoor unit.....	10
Outline & dimension of outdoor unit.....	11
Exploded view of indoor unit .....	12
Spare parts list of indoor unit.....	13
Exploded view of outdoor unit.....	14
Spare parts list of outdoor unit.....	15
Circuit Diagram .....	16
PCB Function Manual.....	17

## TECHNICAL SPECIFICATION

Content		AC-S10CG	
Function		Cooling	
Power supply		1N-50Hz, 220~	
Capacity	W	2600	
Rated input	W	920	
Rated current	A	4.2	
Air flow	M <sup>3</sup> /h		
Dehumidifying volume	L/h	1.2	
EER(W/W)		2.8	
Indoor unit	Motor fan speed(r/min)		1120/920
	Output power(w)		13
	Fan type/piece		Cross flow fan-1
	Diameter-length(mm)		90mm x 538
	Evaporator		Aluminum fin-copper tube
	Row-fin distance(mm)		2-1.5
	Working area(m <sup>2</sup> )		0.13
	Swing motor		MP24GA
	Input/Power(W)		2
	Fuse(A)		Controller 3.15A Transformer 0.2A
	Working capacitor(uF)		1
	Noise(dB(A))		< 37 / = 37
	Dimension(width-height-depth)(mm)		710 x 250 x 180
	Net weight(Kg)		7
Outdoor unit	Input power	W	890
	Current	A	4.0
	L.R.A.	A	18
	Throttling method		Capillary
	Compressor		PH165 X 1C-8DZC2
	Starting method		Capacitor Starting
	Working temp.		<115°C / =115°C
	Condenser		Aluminum fan-copper tube
	Pipe-diameter		9.52
	Row-fin distance (mm)		1-1.6
	Working area		0.3
	Fan motor speed(rpm)		950
	Type-piece		Axial fan-1
	Diameter(mm)		320
	Defrosting method		Auto defrost
	Noise(dB(A))		50
	Dimension(mm)(width-height-depth)		720 x 430 x 260
	Net weight(Kg)		25
Refrigerant charge(kg)		R22/0.60	
Connecting pipe	Length (m)		4
	Outer diameter	Liquid pipe	6(1/4")
		Gas pipe	9.52 (3/8")
	Max distance	Height(m)	5
		Length(m)	10

## PERFORMANCE CURVE

The change relation between low pressure, operation current and temp.  
Cooling operation condition: In testing, indoor and outdoor have same work condition.

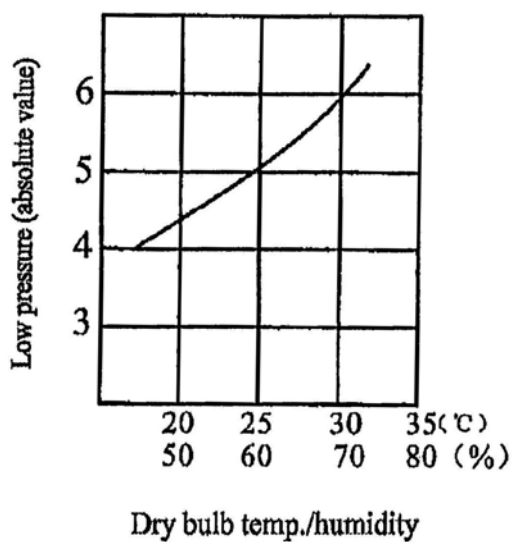

(a)

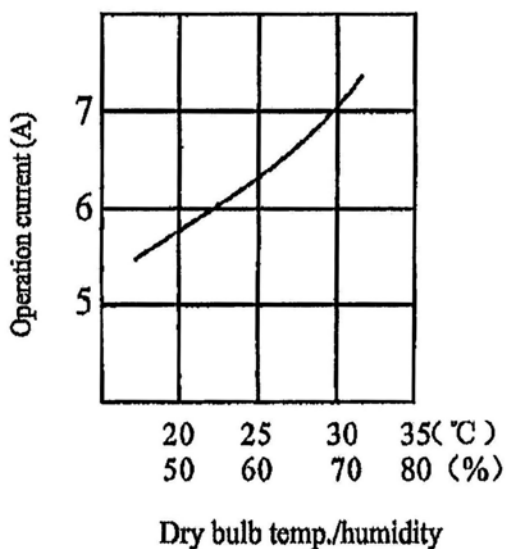

(b)

Heating operation

Indoor work condition: dry bulb temp. 21, wet bulb temp. 15.5 °C .

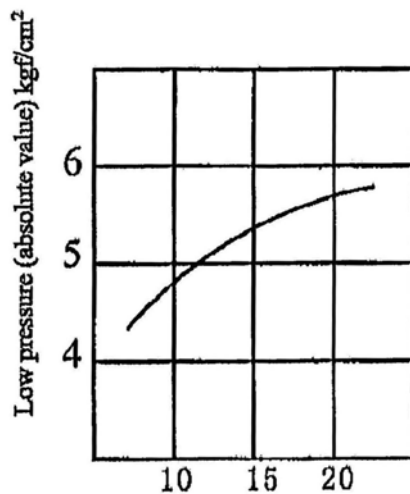

Outdoor dry bulb temp.  
(c)

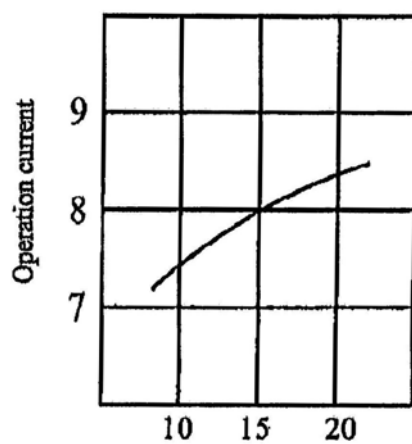

Outdoor dry bulb temp.  
(d)

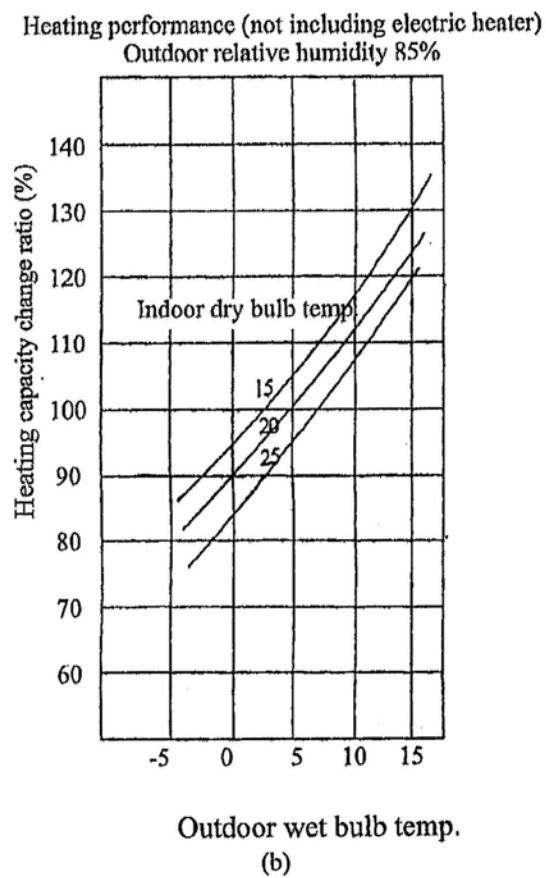
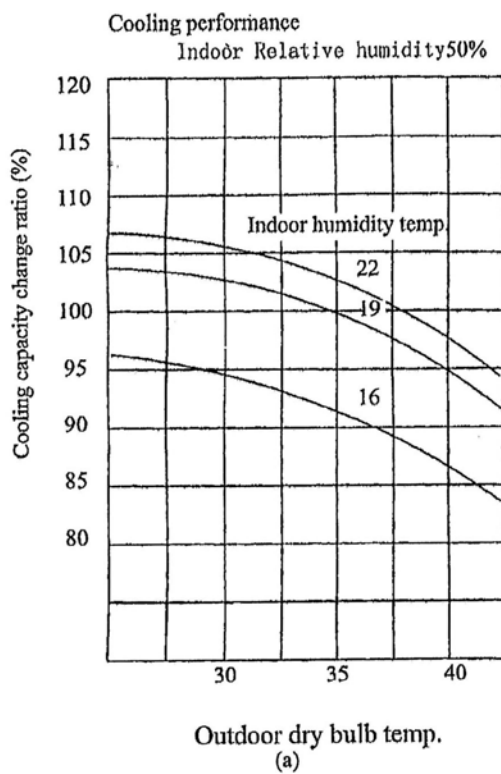

Cooling performance

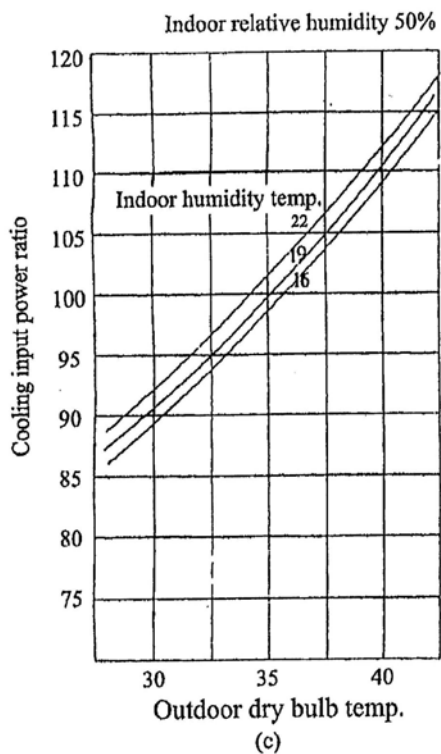

Heating performance (not including electric heater)

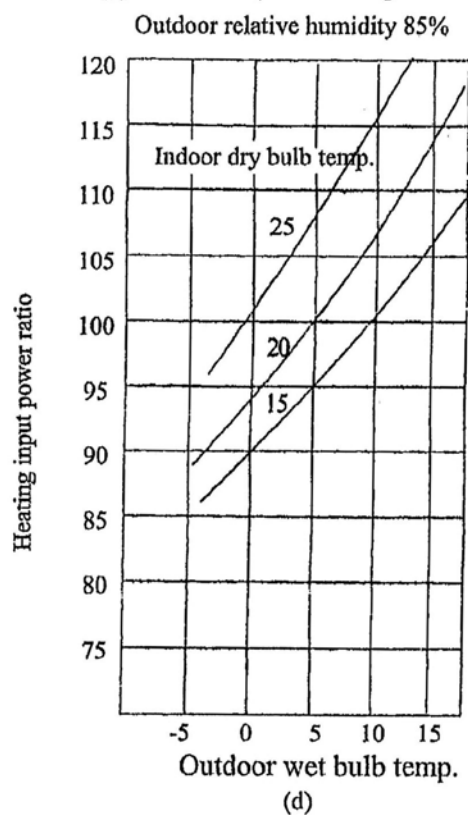



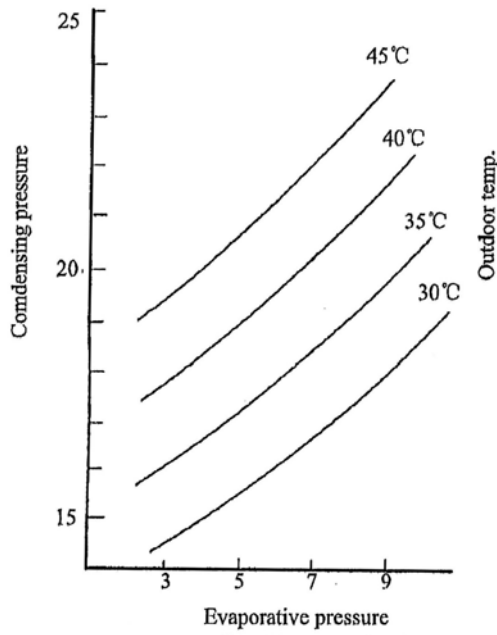

Evaporative pressure

The affection to the charging quantity by pressure under cooling work condition.

The affection to the charging quantity by pressure under cooling work condition.

(Indoor work condition: dry bulb 27°C, wet bulb 19.5°C)

(e)

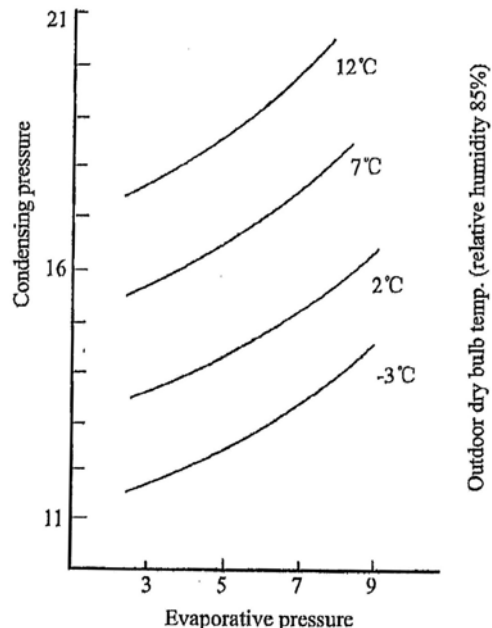

Evaporative pressure

The affection to the charging quantity by pressure under cooling work condition.

The affection to the charging quantity by pressure under cooling work condition.

(Indoor work condition: dry bulb 21°C)

(f)

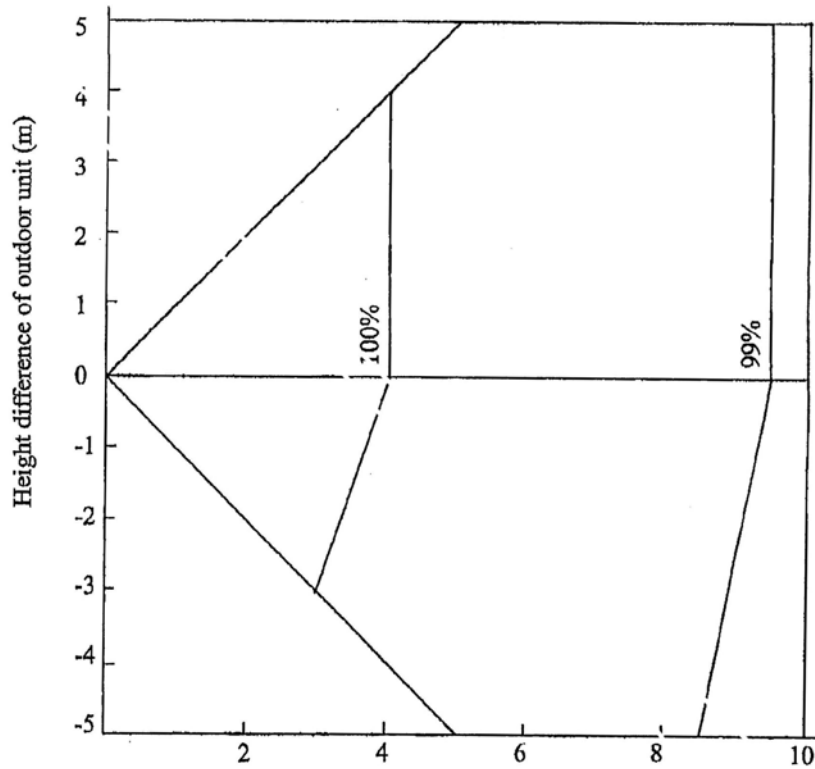

The length of connection pipe

Cooling capacity vary with the length of connection pipe

## OUTLINES AND DIMENSIONS OF INDOOR UNIT

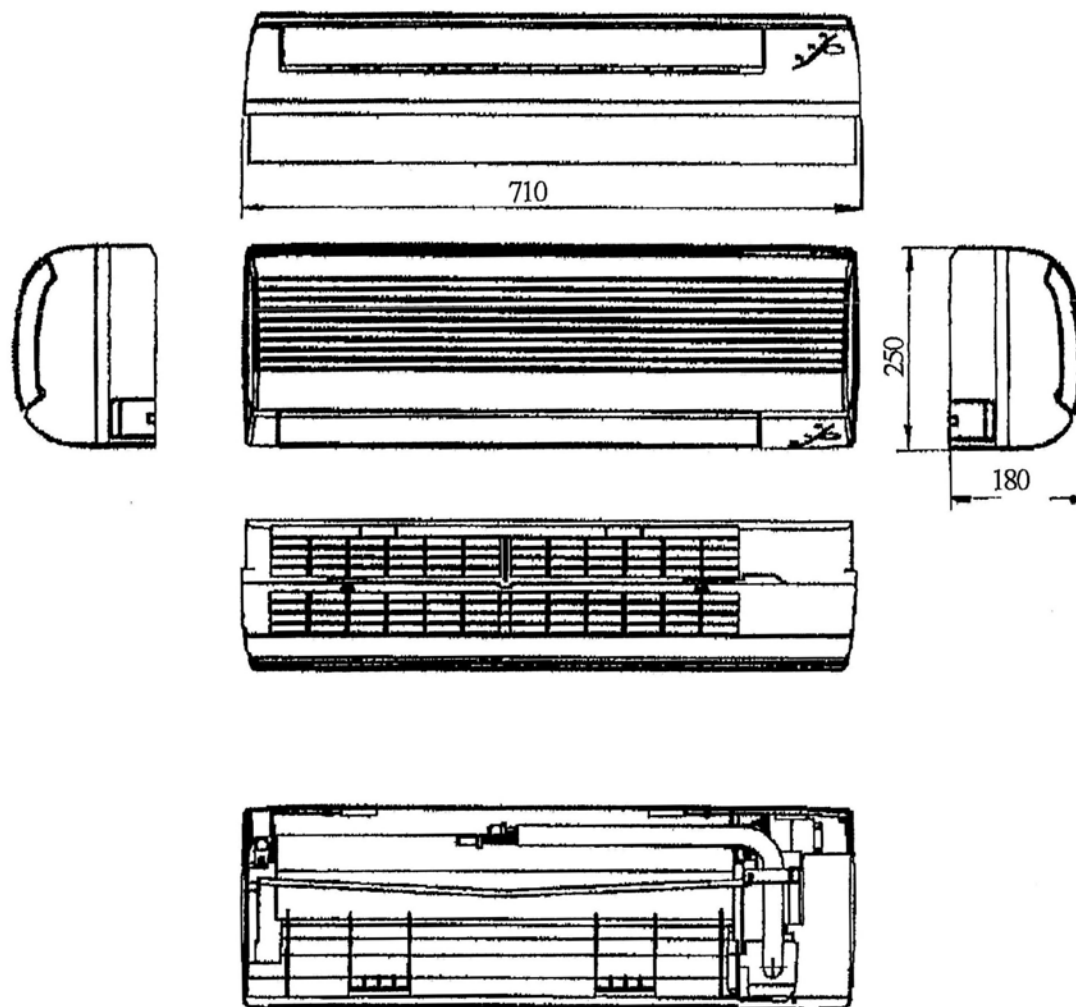

Unit:mm

Ceiling

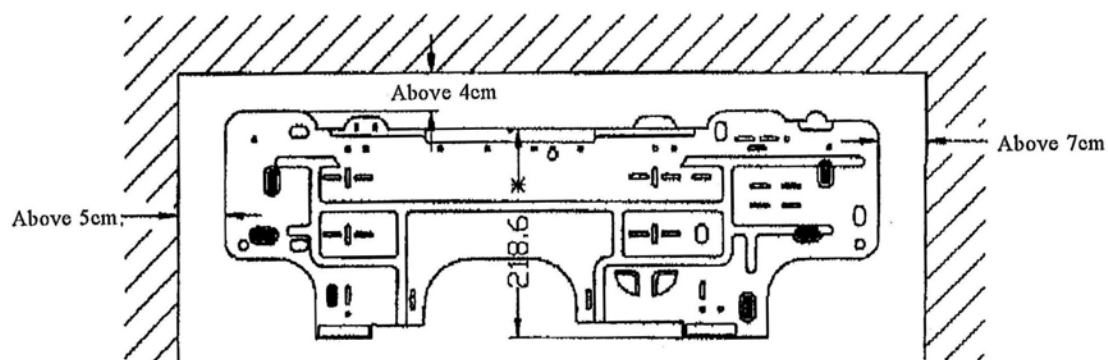

Wall-mounted fram

## OUTLINES AND DIMENSIONS OF OUTDOOR UNIT

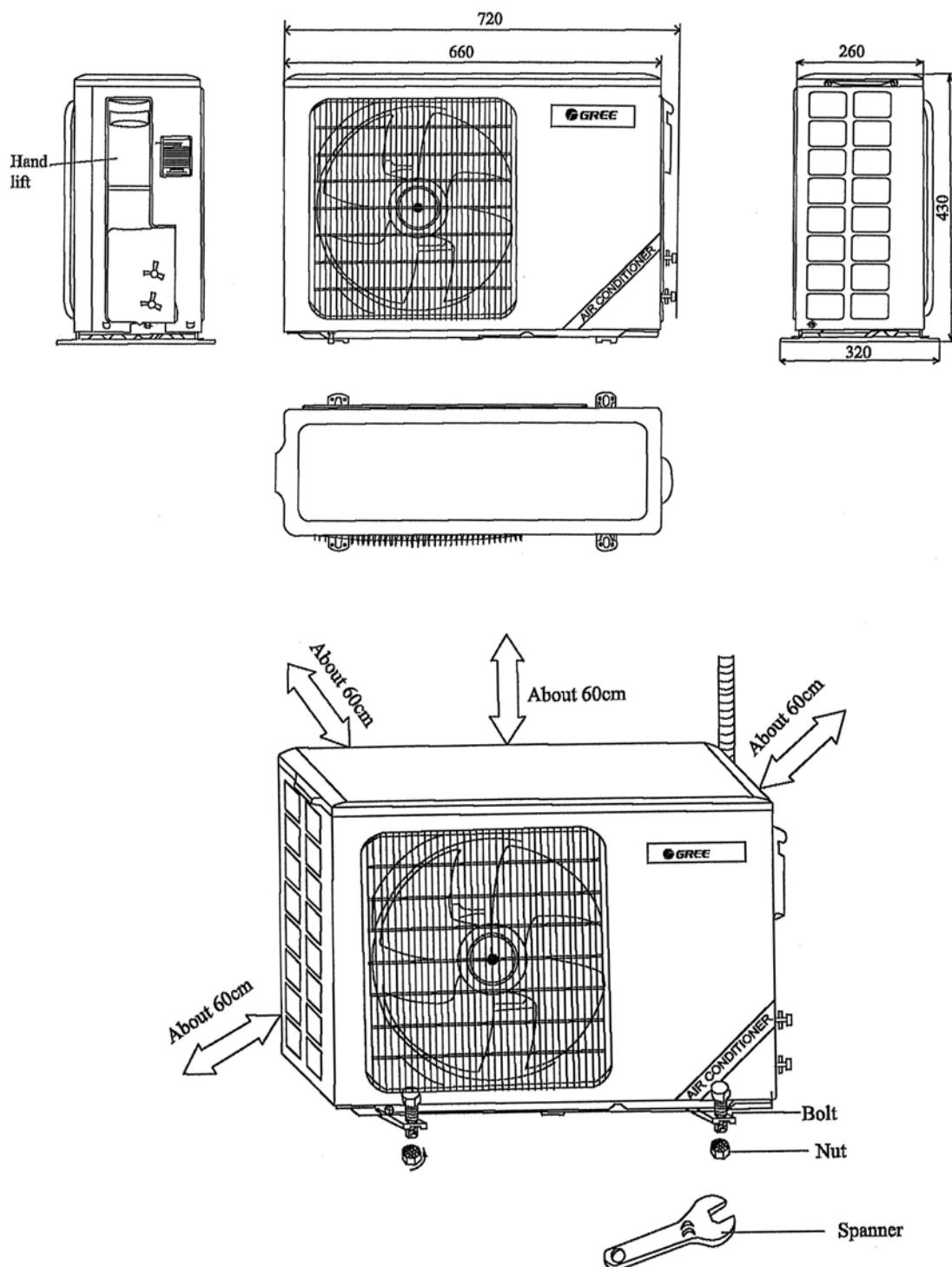

## EXPLODED VIEW OF INDOOR UNIT

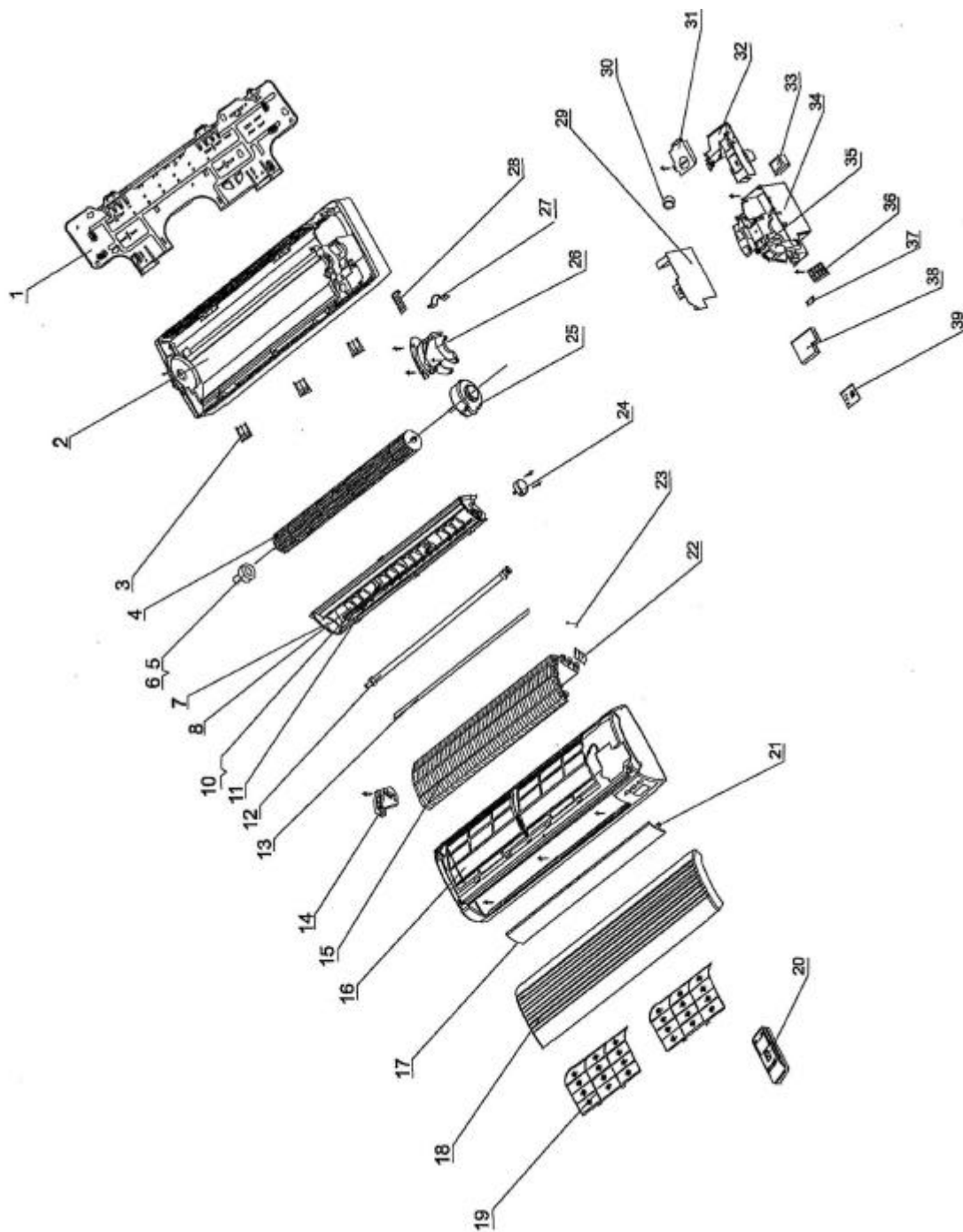

## SPARE PARTS LIST OF INDOOR UNIT

No.	Description	Part No.	Qty
1	Wall-Mounting Frame	01252209	1
2	Rear Case	22202004	1
3	Screw Cover	24252001	3
4	Cross Flow Fan	10352398	1
5	Fan Bearing	76512203	1
6	Ring of Bearing	76512210	1
7	Water Tray Assy	20182015	1
8	Swing Louver	10512002	10
9	Connecting Lever 1	11582004	1
10	Connecting Lever 2	11582005	1
11	Manual Lever	10582001	2
12	Drainage Pipe	05232006	1
13	Evaporator Gate	01072381	1
14	Evaporator Supporter	24212001	1
15	Evaporator Assy	01002056	1
16	Front Case Assy	20002040	1
17	Guide Louver	26112004	1
18	Front Panel	20002035	1
19	Filter	11122006	2
20	Remote Controller	30515002	1
21	Guide Louver Bearing	10542011	3
22	Evaporator Pipe Cover	06122001	1
23	Sensor Insert	42020063	1
24	Stepping Motor MP24GA	15212102	1
25	Motor FN13D	15012045	1
26	motor clamp	26112014	1
27	wire clamp	71010103	1
28	Pipe Clamp	24242001	1
29	PCB 5K91D	30025353	1
30	magnet ring	49010104	1
31	Electric Box Cover 2	20102009	1
32	Electric Box Cover 1	20102008	1
33	Transformer	43110170	1
34	Electric Box	20102010	1
35	Cable Clamp	70482001	1
36	Terminal Board T4A3A7377	42010183	1
37	Wire Clip	70482401	1
38	LED Holder	20182005	1
39	LED Board	30046023	1
40	Room sensor	39000164	1
41	Tube sensor	39000160	1
42	Connecting Cable	40020411	1
43	Power Cord	40020267	1

## EXPLODED VIEW OF OUTDOOR UNIT

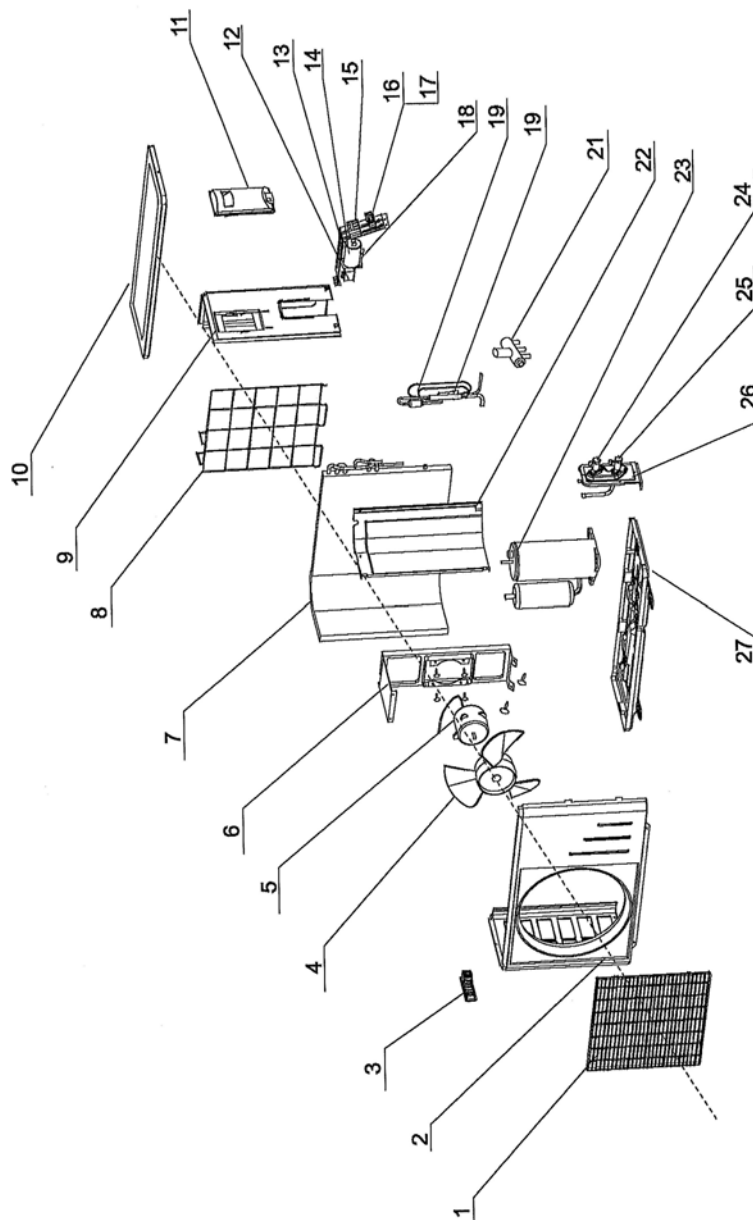

## SPARE PARTS LIST OF OUTDOOR UNIT

No.	Description	Part No	Part No	Qty
1	Front grill	22263002	22263002	1
2	Front plate	20003100	20003100	1
3	Little handle	26233100	26233100	1
4	Axial flow fan	10333002	10333002	1
5	Motor FW20B	15013045	15013045	1
6	Motor support	01703200	01703200	1
7	Condenser assy	01103038	01103166	1
8	Rear grill assy	11123300	11123300	1
9	Right side plate assy	01303150	01303150	1
10	Top cover assy	01253262	01253262	1
11	Handle	26233101	26233101	1
12	Fan motor capacitor 1.5uF/450VAC	33010018	33010018	1
13	Electric box assy	01413034	01413034	1
14	Compressor capacitor 25uF/450VAC	33000017	\	1
14	Compressor capacitor 30uF/450VAC	\	33000018	1
15	Terminal board	42011241	42011241	1
16	Wire clip	24253002	24253002	1
17	Wire seat	24253001	24253001	1
18	Capacitor localizer	02113002	02113002	1
19	Capillary assy	03003106	03003194	1
20	One way valve	\	\	1
21	Reverse valve	\	\	1
22	Clapboard assy	01233100	01233100	1
23	Compressor	00100031	\	1
23	Compressor	\	00120110	1
24	Valve 1/4"	07100125	07100125	1
25	Valve 3/8"	07100143	07100143	1
26	Valve support	01713036	01713036	1
27	Metal base	01203062	01203070	1

## CIRCUIT DIAGRAM

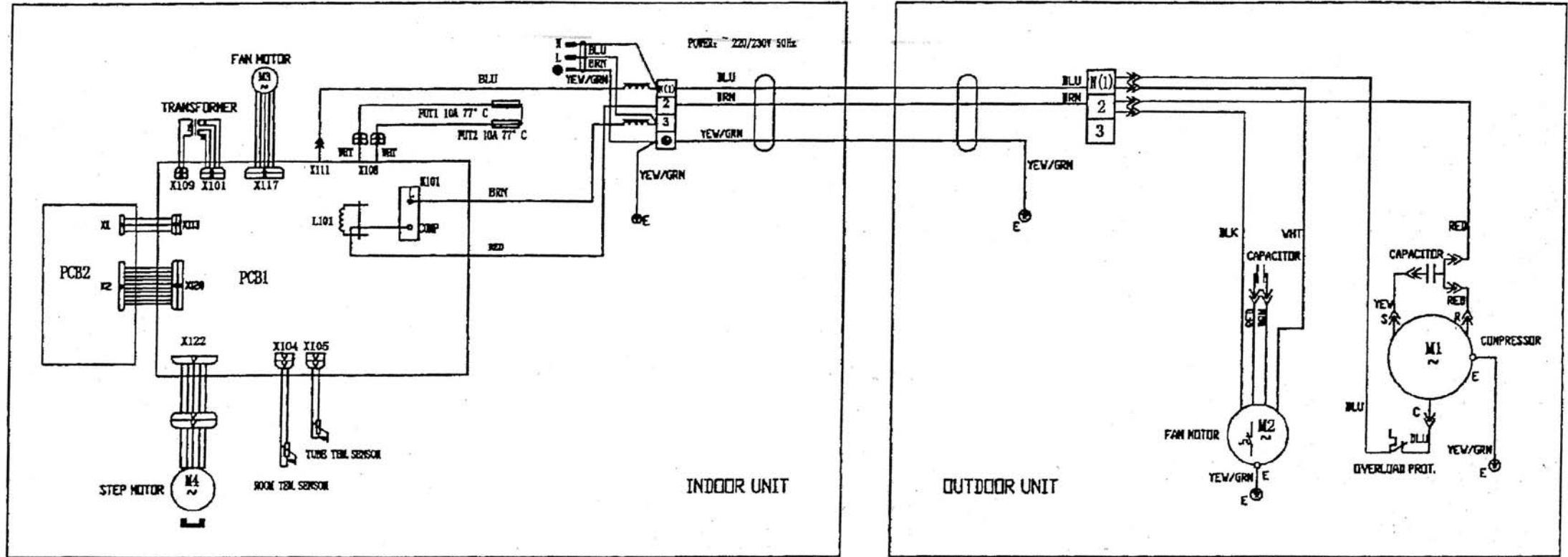



## PCB FUNCTION MANUAL

### 3 In 1 PCB Function manual

#### A. Running mode

1. Cooling
2. Dehumidifying
3. Heating
4. Auto

#### B. Input parameters

1. Indoor ambient temp. T in
2. Evaporator tube temp. T eva
3. Setting temp. T set
4. Condenser tube temp. T con

#### C. Targets

1. Indoor motor ( motor )
2. Swing motor
3. Outdoor motor ( single speed motor)
4. Compressor
5. Four-way reversing valve
6. Cooling, dehumidifying indicator; running indicator
7. Digital tube setting temp. indicator or timer indicator

#### D. Fundamental functions

##### Cooling mode

- 1 The running conditions and control measures
  - a. If  $T_{in} > \text{or} = T_{set} + 1^{\circ}\text{C}$  , the machine runs at the cooling mode. Compressor runs, outdoor motor runs at low speed , indoor fan runs at the set fan speed.
  - b. if  $T_{in} > \text{or} = T_{set} - 1^{\circ}\text{C}$  , the machine stops. Compressor stops first, outdoor motor stops after 15 seconds, indoor motor runs at the set fan speed.
  - c. if  $T_{set} - 1^{\circ}\text{C} < T_{in} < T_{set} + 1^{\circ}\text{C}$  ,keep the previous state.
- 2 In this mode, the reversing valve is inactive, the temp. setting range is from 16~30°C.
- 3 Protect function
  - a. Anti-freezing function.
    - i. If compressor have run 6 minutes , and detect  $T_{eva} < 0$  for continuous 3 minutes, then the compressor outdoor fan stopped , indoor fan run at the set fan speed. After 3 minutes later, it will run at the original state if  $T_{eva} 10^{\circ}\text{C}$ .
  - b. Compressor protection
    - i. Compressor's starting interval should be more than 3 minutes no matter in what-ever modes and conditions. If it's plugged in first time, the compressor does not have 3 minutes delay. When compressor is started, it will not stop within 5 minutes unless it is plugged out.

- c. Overload protection
  - i. If it detect the system current surpass the designed 13 A for continuous 3 minutes, the machine go into fan mode, when 3 minutes passed and it detect the current no more than 13 A, it will back to original state. If it detects overloading states for 6 consecutive times, the machine stops, and must be restarted by remote controller.

### **Dehumidifying mode**

- 1 The working conditions and control measures
  - a. If  $T_{in} > T_{set} + 2^{\circ}\text{C}$  , it is in cooling running, the indoor motor speed can be selected, and outdoor motor run at low speed.
  - b. If  $T_{set} - 2^{\circ}\text{C} < \text{or} = T_{in} < \text{or} = T_{set} + 2^{\circ}\text{C}$  ,it goes into dehumidifying running ,the indoor motor run at the low speed, 6 minutes later the compressor stops, another 15 seconds later the outdoor fan stops and another 30 seconds later, the indoor motor stops, 3 and a half minutes later, compressor and outdoor fan run again ,indoor motor runs at the low speed, then the machine cycle the above procedures repeatedly. outdoor motor runs at the low speed.
  - c. If  $T_{in} < T_{set} - 2^{\circ}\text{C}$ , compressor ,outdoor motor and indoor motor stop.
- 2 In this mode, the reversing valve is inactive , the temp. setting range is 16~30 .
- 3 Anti-freezing protection.
  - a. If  $T_{indoor} > T_{set} + 2^{\circ}\text{C}$ , it goes into cooling running , anti-freezing function is same with cooling mode, but the compressor must stops for 4 minutes. when it goes into dehumidifying mode, compressor runs 6 minutes , if it detects  $T_{eva} < 0^{\circ}\text{C}$ , compressor and outdoor motor stop, indoor motor runs at low speed ,after 3 minutes delay, and  $T_{eva} > \text{or} = 10^{\circ}\text{C}$ , it will be back to its original state.

### **Heating mode**

- 1 The working conditions and control measures
  - a. If  $T_{in} < \text{or} = T_{set} + 2^{\circ}\text{C}$ , it goes into heating mode, reversing valve, compressor and outdoor motor all work in the same time, indoor fan will run at the same procedures with anti cool air function.
  - b. If  $T_{in} > \text{or} = T_{set} + 4^{\circ}\text{C}$  , compressor stops first, 15 seconds late, outdoor motor stops, but reversing valve keeps working, indoor motor run at the procedures of blowing surplus heat.
  - c. If  $T_{set} + 2^{\circ}\text{C} < T_{indoor} < T_{set} + 4^{\circ}\text{C}$  , keep the previous running state.
- 2 In this mode, the temperature setting range is 16~30°C.
- 3 The working conditions of auxiliary electric heater.
  - a. In heating mode, when compressor is working, indoor motor runs at high speed and middle speed. If it detect  $T_{eva} < 50^{\circ}\text{C}$  for continuous 8 seconds and  $T_{indoor} 25^{\circ}\text{C}$ , electric heater will work, if compressor stop or indoor motor runs at low speed or  $T_{eva} > \text{or} = 54^{\circ}\text{C}$  or  $T_{indoor} > \text{or} = 28^{\circ}\text{C}$  or 10 seconds before defrosting , the electric heater will stop.
- 4 Protections
  - a. Anti cool air
    - i. when the machine starts heating and  $T_{eva} > \text{or} = 22^{\circ}\text{C}$  , indoor motor runs at low speed, and swing motor makes the louver at the horizontal position (in Bird line, it will swing to the maximum air volume position), if  $T_{eva} > \text{or} = 40^{\circ}\text{C}$  or compressor have run 2 minutes ,indoor motor and swing motor will run at the set speed.

- b. Anti high temp.
  - i. In heating mode, if it detect T eva 56°C (58°C can be selected), outdoor motor will stop (in this period it will not detect the defrosting temp.). If T eva < or = 52°C, outdoor motor will be back running (it will not detect defrosting temp. in the first 5 seconds).
- c. Blowing surplus heat
  - i. In heating mode, when set temp is reached ,comp. stops first,15 seconds later outdoor fan stops, Indoor motor blows 90 seconds (60 seconds can be selected) at low speed ,swing motor makes the louver at the horizontal position.
- d. Compressor's protection is same with the one in cooling mode.
- e. Overload protection
  - i. If it detects that the system current surpassed the designed 13 A for continuous 3 seconds, compressor, electric heater and outdoor motor stop , indoor motor runs the same procedures as the blowing surplus heat condition. After 3 minutes and current no more than 13 A, the machine will be back to its original state, indoor motor runs as the anti cool air condition. If it detects overloading state for 3 consecutive times within 30 minutes, the machine stops, and it must be restarted by remote controller.
- f. Defrosting conditions and procedures
  - i. In heating mode, if compressor has run 44 minutes ( in its first 6 minutes it will not detect defrosting temp.), and it has detected T con < or = -4°C for continuous 1 minutes, it begins to defrost, electric heater will stop for 10 seconds ( even if electric heater is not working), then indoor motor stops, reversing valve becomes inactive in another 2 seconds, another 2 seconds later, outdoor motor stops, when T con > or = 10°C or defrosting lasts for 10 minutes , outdoor motor and reversing valve becomes active , indoor motor will run as the anti cool air condition, then it cycles again, recalculates the compressor's running time again. (In this period , if any protection works ,and after the machine is back to work , it will re-start defrosting state. it will not detect outdoor tube temp when compressor's in its first 6 minutes running )
- g. Noise eliminated protection
  - i. When you use RUN/STOP button to switch off the machine, reversing valve will become inactive in 2 minutes.

### **AUTO mode**

- 1 In AUTO mode, standard cooling T set = 25°C, standard heating T set = 20°C.
- 2 Working procedures
  - a. If T indoor > or = T set + 1°C , select cooling mode, from this time, the set temp. is 25°C. If < or = T indoor T set -1°C, compressor and outdoor motor stop, indoor motor runs at the set speed, if T set -1°C < T indoor < T set + 1°C , keep the original state.
  - b. If T indoor < or = T set + 2°C , select heating mode, from this time, the set temp. is 20°C , if T indoor > or = T set + 4°C, compressor stops first, outdoor motor stops 15 seconds later , reversing valve is always active, indoor motor runs as the blowing surplus heat condition. If T set + 2 < T indoor < T set + 4°C, keeps the original state.  
Cooling only AUTO mode: there is no heating function in this mode.
- 3 Protections
  - a. It is same as the one in cooling or heating mode.

**Other controls**

- 1 SWING mode
  - a. When it is active, the louver returns to position O, close the air outlet.
  - b. When machine works, it turns to the max. Air output position D, then returns back to position L to stand by (position L is the horizontal place mentioned before).
  - c. In swing state, the louver swings between position L and position D.
  - d. When the machine is switched off, it is back to position O.
  - e. When the machine is running and the swing is off, the louver stops at position E.

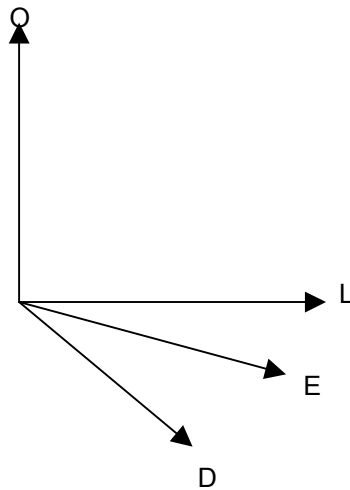

- 2 Beeper
  - a. When PCB becomes active or receives the signal from the remote controller , the beeper will beep.
- 3 Indication lams
  - a. It flashes when defrosting begin.
- 4 Press the AUTO button a time, the machine runs in AUTO mode, indoor motor runs in low speed, fresh air function is not active, press again the machine stops.
- 5 Digital tube display
  - a. the digital tube displays the setting temperature (the range is 16~30°C) when the machine is running
  - b. The digital tube displays the setting time (the range is 1~24 hours) for 5 seconds when remote controller sets timer of on/off. Then come back to display the setting time; timer displays “—“, it means that timer setting is canceled.
  - c. Light button: when remote controller(Y512) sends light signal, the digital tube is lighted for 2~4 seconds then turns off.
- 6 Fresh air function.
  - a. There are two fresh air modes.
    - i. fresh air 2 === fresh air motor will work 1 hour, then rest 1 hour, then cycle again.
    - ii. fresh air 1 === press the button AIR on the remote controller to select fresh air 1 function, the swing motor keeps running till you give a signal to change it.

- 7 Automatic fan speed.
  - a. In cooling mode, if  $T_{\text{indoor}} > T_{\text{set}} + 5^{\circ}\text{C}$  high speed  
 $T_{\text{indoor}} > \text{or} = T_{\text{set}} + 3^{\circ}\text{C}$  middle speed  
 $T_{\text{indoor}} > \text{or} = T_{\text{set}} + 1^{\circ}\text{C}$  low speed
  - b. In dehumidify mode, if  $T_{\text{indoor}} > \text{or} = T_{\text{set}} + 5^{\circ}\text{C}$  high speed  
 $T_{\text{indoor}} > \text{or} = T_{\text{set}} + 2^{\circ}\text{C}$  low speed
- 8 SLEEP mode.
  - a. In cooling or dehumidifying mode, 1 hour after you set the sleep timer, T set will add  $1^{\circ}\text{C}$  automatically, another 1 hour, another  $1^{\circ}\text{C}$  will be added.
  - b. In heating mode, 1 hour after you preset the sleep timer, T set will lower  $1^{\circ}\text{C}$  automatically, another 1 hour, another  $1^{\circ}\text{C}$  will be lowered.



**Большая библиотека технической документации**

<https://splitsystema48.ru/instrukcii-po-ekspluatácii-kondicionerov.html>

**каталоги, инструкции, сервисные мануалы, схемы.**